

ELECTRIC STRIKE

GS-2000

Product Synopsis

Electric strike is an access control device used for doors. GS-2000 electric strikes are high security products manufactured from stainless steel and designed for use with all access control systems. These strikes are flexible and can be changed from fail safe to fail secure.

GS-2000

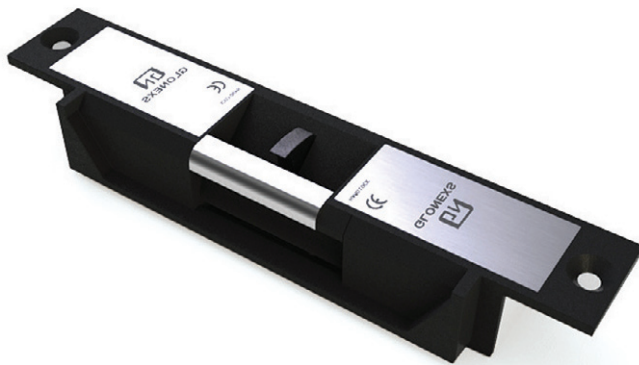

■ Dimensions

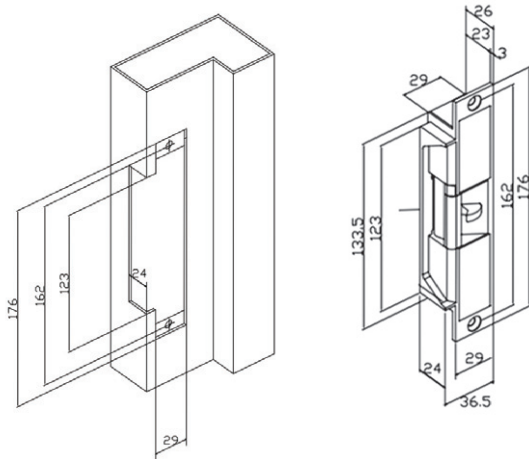

■ Power to lock / Power to open

Fail Safe(Power to lock)



A factory setting is power to open

Fail Secure(Power to open)



Unscrew the solenoid connection, turn over like a red circle

■ Specifications

Item	Spec
Voltage/Current	12/24VDC, 180mA
Door Monitoring	COM, NO, NC
(Locking monitoring)S/W	COM, NO, NC

■ Functions

- Fail safe / Fail secure
Changeable on-site
- Dual Monitoring
- GS-2000 has both solenoid and latch/door monitoring
solenoid Monitor-3amp NO/NC microswitch
door/latch monitor -3 amps NO/NC microswitch
- Holding force
1200Kg
- material
Stainless Steel Body

■ Size & Weight

- Size : 176(L)x 29(W)x 24(D)mm
- Weight : 479g

■ wiring

	ITEM	Section
solenoid	DC12V	Red, black
	N.C	Yellow
	N.O	Brown
Door Monitoring	COM	Purple
	N.C	White
Strike (Solenoid Monitoring)	N.O	Gray
	COM	Orange